

Specifications	
Description	Lifts and tips trays of product into a hopper or conveyor
Bin Type	Most sizes of trays
Safe working load	55 lb
Lifting speed	80ft/min (16"/second)
Power supply	480 volt, 3PH, 60Hz
Control voltage	24V AC
Operating environment temperature	15°F to 105°F
Controls	Automatic
Drive type	Braked gear motor and timing belt
IP rating	IP65 minimum
Safety features	Magnetic safety switches on drop-down gates. Solenoid lock switch on access door. Light sensor prevents operation if tray is out of position.

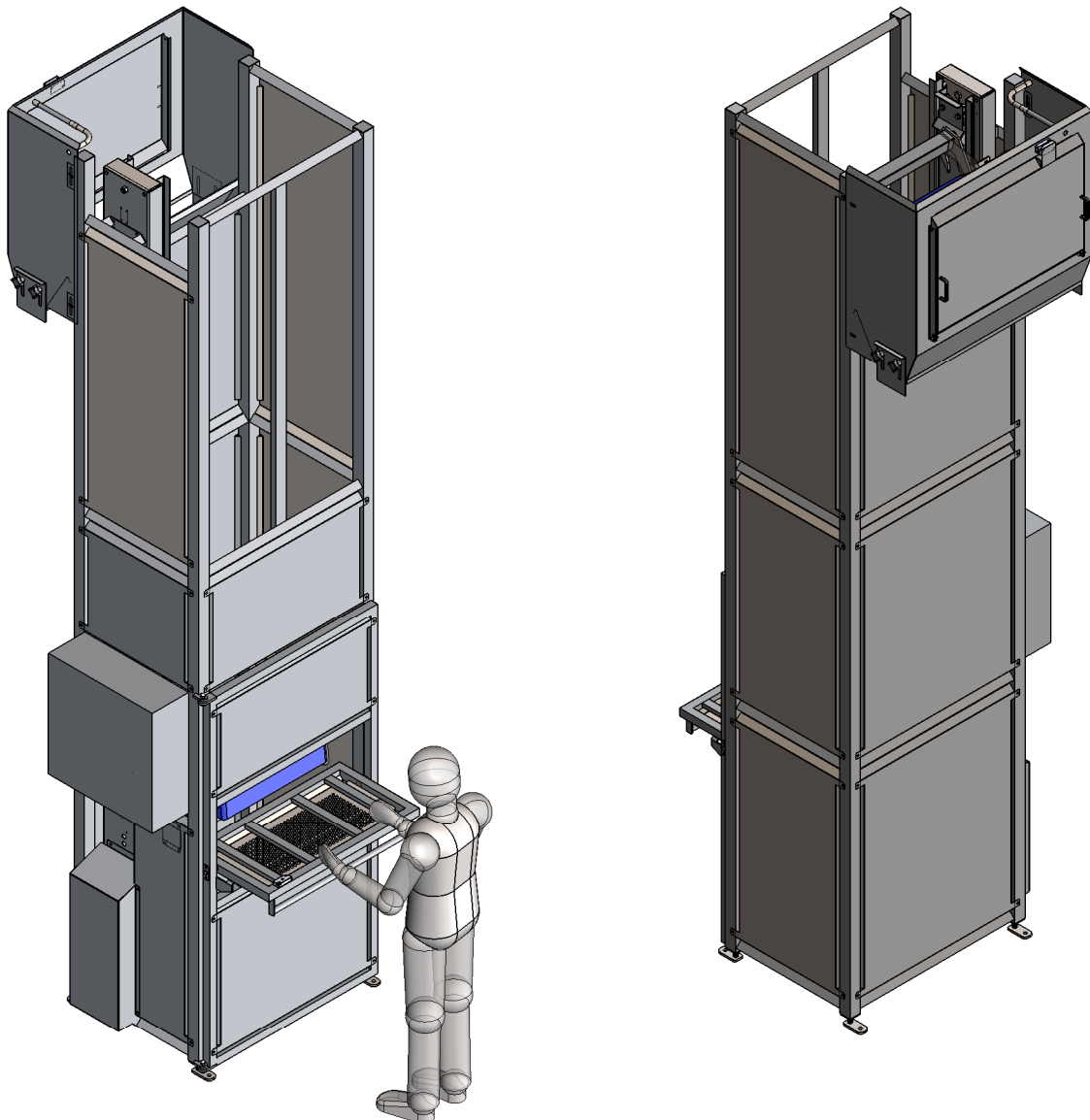

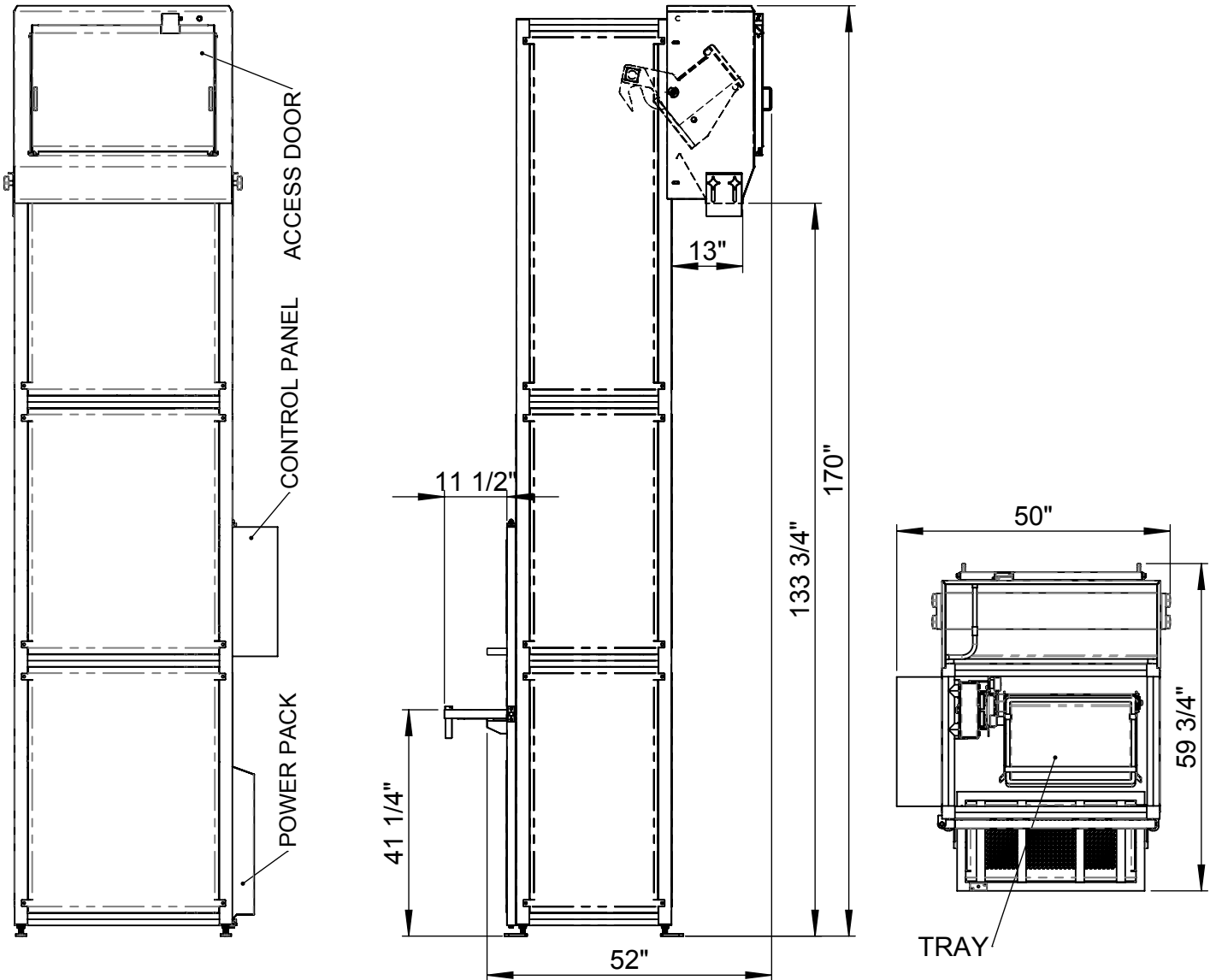

Information required	
Headroom	Minimum clearance under ceiling, lights, pipes etc
Access for installation	Dimensions of corridors and doorways. Availability of lifting equipment in the area
Tray type	Overall dimensions
Outfeed	Hopper height
Throughput	Required throughput in lb per hour
Product type	Product name, characteristics and bulk density

235 Benjamin Drive Suite 102, Corona, California, CA 92879



☎ (951) 808-4376
 ✉ SALES@CMPSOLUTIONS.NET